

SHEET NOTES:

1. CONTROL CONSOLETTA
2. COUNTERMATE MOTOR CONTROL CABINET (MCC)
3. COUNTERMATE WINCH ENCLOSURE
4. ARBOR WEIGHT
5. CONSOLETTA DATA CABLE
6. CONSOLETTA POWER CABLE
7. WINCH POWER CABLE
8. POWER/DATA RACEWAY
9. CONFIGURATION TYPICAL FOR 30x COUNTERWEIGHT LINESETS

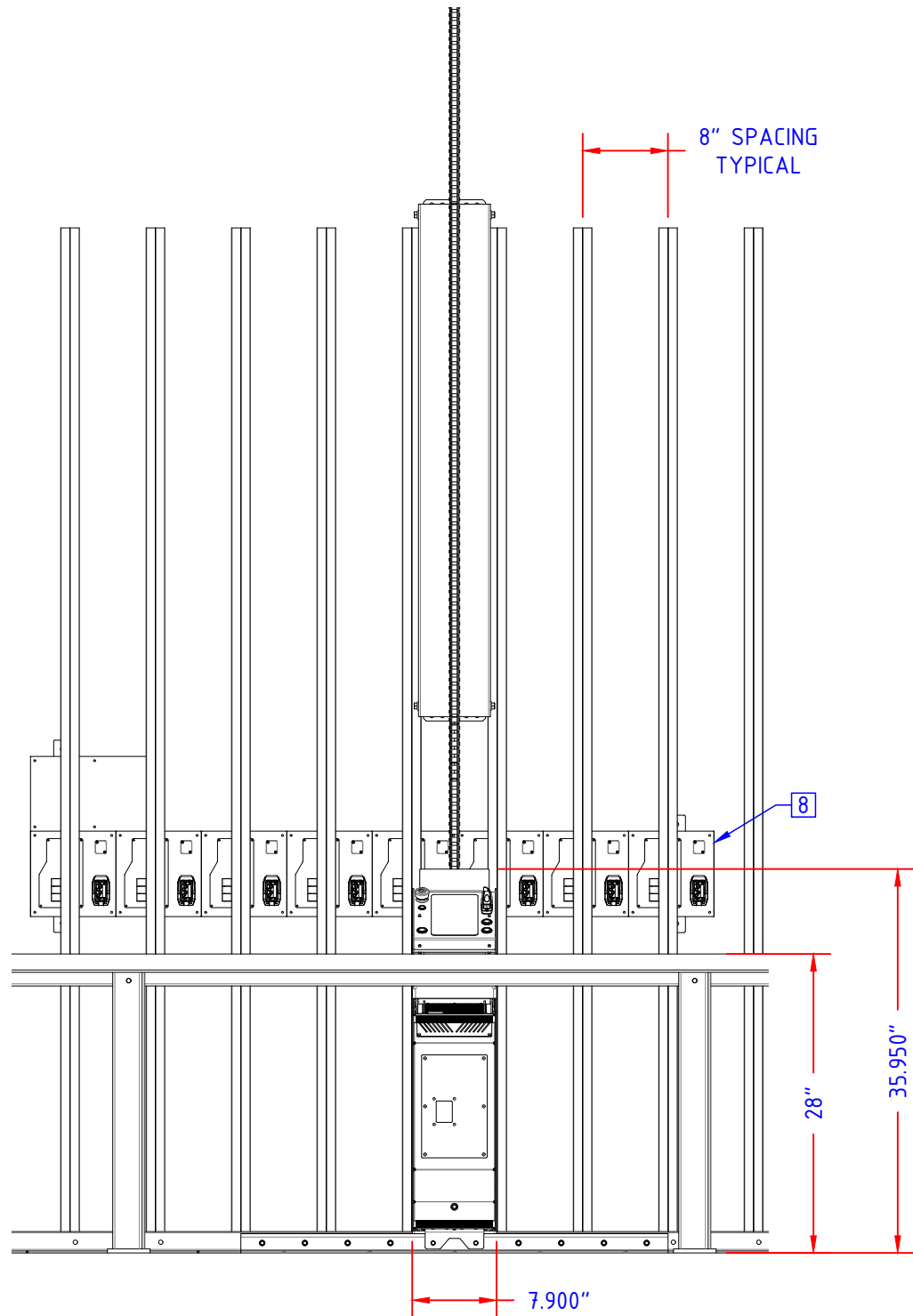

1. FRONT VIEW  
SCALE 1:16

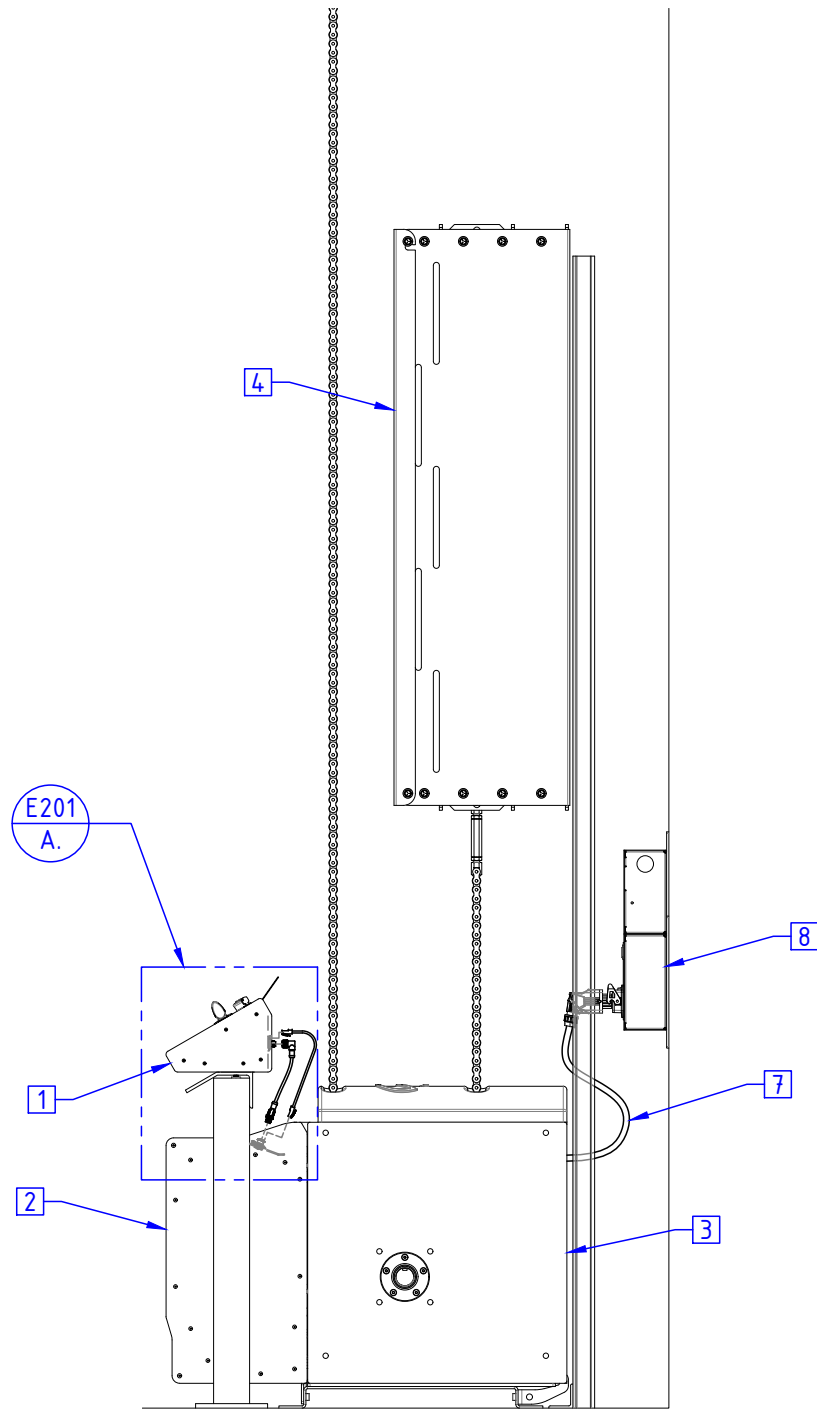

2. RIGHT SIDE VIEW  
SCALE 1:16

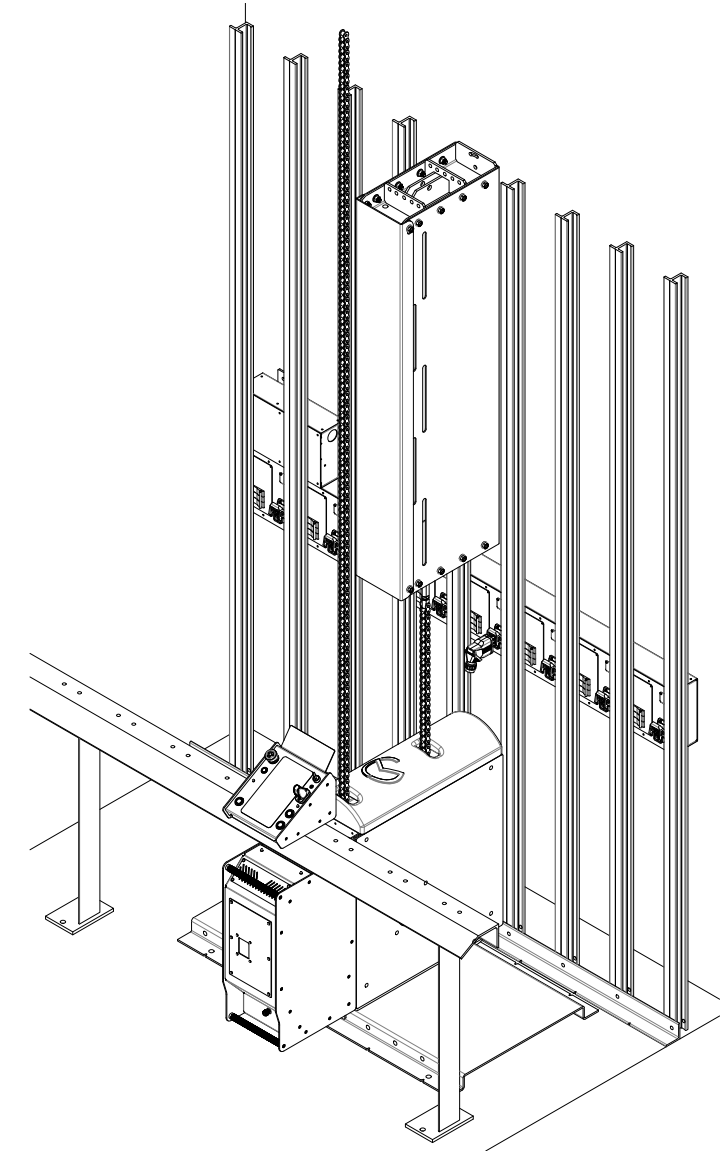

3. ISOMETRIC VIEW  
NOT TO SCALE

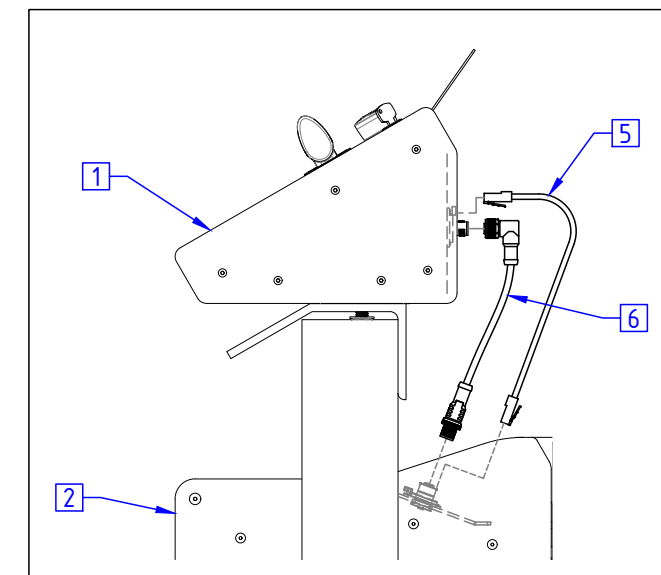

DETAIL A. CONSOLETTA CABLES  
SCALE 1:6

THIS DOCUMENT CONTAINS INFORMATION PROPRIETARY TO PROTECH TECHNICAL SERVICES, INC. ALL RIGHTS OF DESIGN, PATENTS AND/OR INVENTIONS ARE RESERVED BY PROTECH TECHNICAL SERVICES, INC. FOR DESIGN AND MANUFACTURING PURPOSES WITHOUT PRIOR WRITTEN PERMISSION FROM PROTECH TECHNICAL SERVICES, INC.

3431 NORTH BRUCE STREET  
NORTH LAS VEGAS, NV 89030  
702-639-0290  
protechlv.com

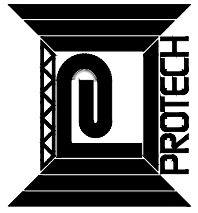

REVISIONS  
Q. 11/18/2024 As Built

ARCHITECT :  
CONSULTANT :  
CONTRACTOR :

PROJECT  
COUNTERMATE PRO

SHEET TITLE  
CUT SHEET

DATE  
12/04/2024  
FILE  
CM\_installation  
DRAWN BY  
MK  
CHECKED BY  
RM

